

squareline drinking fountain

The **Veitch Squareline Pedestal Drinking Fountain** is a square freestanding single station drinking fountain particularly suited for use in places such as schools, recreation centers and public spaces.

This drinking fountain provides non-refrigerated drinking water and is supplied with a sturdy vandal-resistant bubbler, suitable for water pressure up to 400 Kpa, which should be connected to the water supply via a stop tap and pressure relief valve if required.

Available in either a 725mm or 900mm height, this unit comes with a 40mm dia. PVC waste outlet and has four (4) mounting holes in the base for easy installation, accessible via a flush mounted panel at the rear of the unit.

The Veitch Squareline drinking fountain is manufactured entirely from 1.2mm Grade 304 stainless steel in a complete one piece construction, ensuring maximum cleanliness and minimal maintenance. It is 100% Australian made and is fully recyclable.



The Veitch Squareline drinking fountain comes complete with sturdy bubbler and PVC waste.

A flush mounted panel at the rear of the unit allows for access for installation and maintenance.

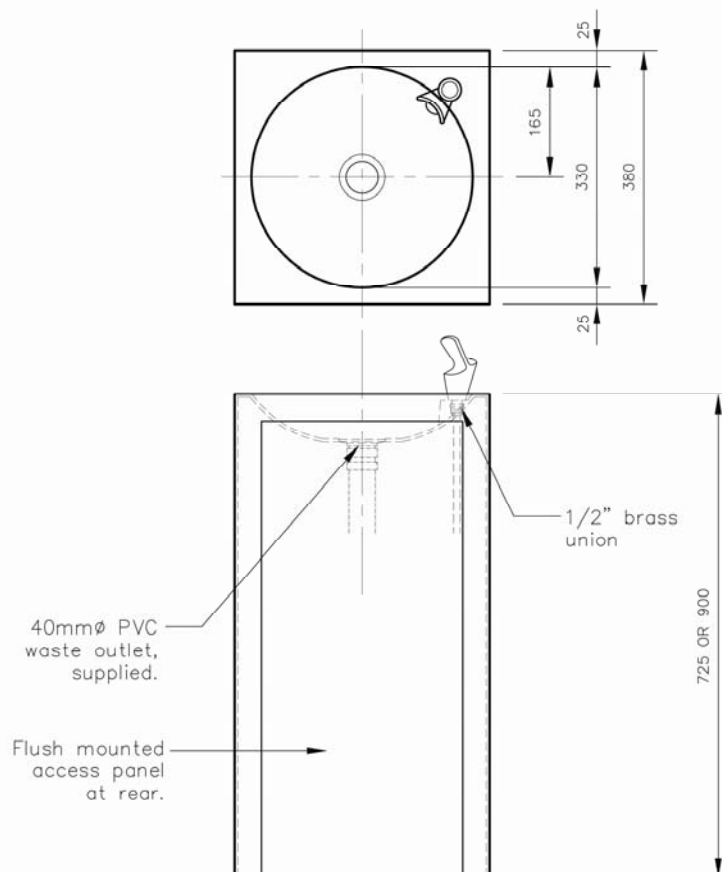

Designed & manufactured in Australia.

veitch
quality stainless steel products

address: 51 Commercial Drive
Thomastown, Vic. 3074
phone: 03 9465 4131
fax: 03 9465 1478
email: enquiries@veitchstainless.com.au
web: www.veitchstainless.com.au

PRODUCT CODES:

04-2223 Squareline drinking fountain,
725mm high
04-2234 Squareline drinking fountain,
900mm high

REVISION:
August 2010

**commercial
standard products**

2.7